

# Instruction Manual

## CVS 7970 High-Low Pressure Pilot

### Introduction

This instruction manual includes the following information for CVS 7970 High-Low Pressure Pilot:

1. Description
2. Piston Arrangement Changeover Instructions
3. Parts Information

Only persons qualified through training or experience should install, operate and service this equipment. If you have any questions regarding this product or this manual, please contact your CVS Controls Sales Representative before proceeding.

### Description

The CVS 7970 is a versatile sensor that can be programmed to detect and react to either increasing pressure or decreasing pressure with an adjustable range of 2 to 10,000 PSI (.138 to 689.5 bar).

When used within standard safety systems, a pressure sensor monitors a specific media or process pressure source for changes to the normal operating range. Loss of pressure within the control circuit will begin a shutdown sequence or trigger an alarm, and pressure sensors can also indirectly operate on/off flow control valves or pneumatic driven pumps.

The CVS 7970 is a two position, three-way pilot with universal ports (H, O, L), automatic reset (spring return) and pressure balance spool.



**Figure 1: CVS 7970 High-Low Pressure Pilot**

Each CVS 7970 is a self-contained unit containing necessary components for four different piston arrangements. Changeover instructions and drawings are included in this manual. Parts which are not installed in your current piston arrangement are kept in an enclosed storage tube. Machined within the piston housing of the CVS 7970 is a convenient 1/8"–27 NPT Female process connection and 1/2" NPT Male process connection.

**Head Office**  
3900 – 101 Street  
Edmonton, Alberta, Canada T6E 0A5  
Office: (780) 437-3055  
Fax: (780) 436-5461

**CVS**  

---

**Controls Ltd.**

**Calgary Sales Office**  
205, 2323 – 32 Avenue NE  
Calgary, Alberta, Canada T2E 6Z3  
Office: (403) 250-1416  
Fax: (403) 291-9487

Website: [www.cvs-controls.com](http://www.cvs-controls.com) E-Mail: [info@cvs-controls.com](mailto:info@cvs-controls.com)

**Table 1: CVS 7970 Specifications**

Characteristic		Dimensions
<b>Dimensions</b>		1.750" diameter x 8.0" length
<b>Working Pressure</b>	Process Pressure Inlet	10,000 PSI Maximum (689.5 bar)
	Control Ports	125 PSI Maximum (8.62 bar)
<b>Connections</b>	Process Pressure Inlet	1/2"-14 NPT M and 1/8"-27 NPT F
	Control Ports	1/4"-18 NPT F
<b>Weight</b>		3.5 lbs / 1.6 kg
<b>Panel Hole Cutout Size</b>		1 5/8" (39.81 mm)
M=Male, F=Female		

**Introduction continued**

One particular advantage of the CVS 7970 is its adjustment range capability. Because of the complete supplied components, there is no need to purchase and store additional sets of matching piston and spring components. The installation or reorientation of the existing piston components allows for an adjustment range capability of 2 to 10,000 PSI. This is especially convenient for remote facilities which require changes to pressure settings to match changes in process conditions.

The CVS 7970 is available in a High-Low configuration using two pilots mounted and tubed to a carbon steel or stainless steel manifold (Figure 8). Your choice of 2-1/2" NPT process or gauge connections are available. This design allows for completely independent setting of the high and low pilots spanning the range of 2 psi to 10,000 psi. This configuration is available in Auto Reset (not shown) or Manual Reset (shown, pg 8).

**Piston Arrangement Changeover Instructions**

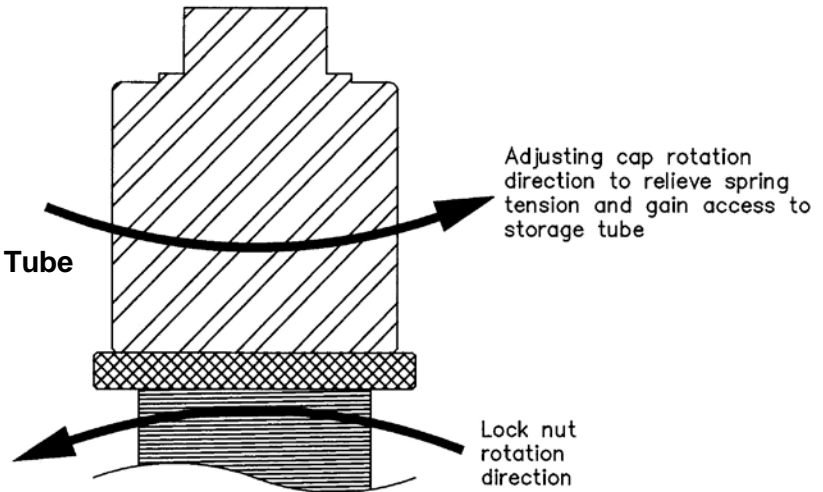
The information in this manual, including the parts listings and piston detail drawings, will assist you in completing the Piston Arrangement Changeover.

**Caution: Consult and follow the established safety procedures of your facility prior to beginning disassembly of any CVS Controls product. Ensure that all pressure is exhausted from the system prior to performing any service work. Failure to remove the pressure from the system can result in serious personal injury.**

1. Isolate and depressurize the control system.
2. Disconnect the control circuit instrumentation tubing from control valve, as well as the monitored process connection from the piston housing.
3. Where possible, remove the CVS 7970 from the service location to perform the changeover in a clean work environment.

4. Loosen the lock nut and remove from the adjusting cap. (See figure 2)
5. Gently relieve all spring tension by fully unscrewing the adjusting cap. This allows access to the storage tube.
6. Unscrew the piston housing from the valve body.
7. Turn the piston housing upside down and tap it gently on a flat, clean surface to remove the piston arrangement. The pistons should slide out easily.
8. Thoroughly clean the piston components, including the piston housing and internal bores, using warm water and a liquid detergent. Do not use abrasive tools or acidic cleansers. Dry all components with a cloth or paper towel.
9. Lightly lubricate all components and seals, and assemble the piston arrangement as desired according to the enclosed detail drawing.
10. When inserting the new piston arrangement into the piston housing, apply even pressure. Press evenly using both thumbs on the piston's outer edges for the insertion of the 1-1/8", 1/2" and 3/16" piston arrangements.
11. For the 1/4" piston insertion, install the 1/4" piston first, using a needle-nosed pliers. Then press the other piston components into place.
12. Lightly lubricate the threads of the piston housing, body and spring housing. Be sure to use a grease or medium appropriate for stainless steel.
13. Reassemble the pressure pilot.
14. Adjust the pressure setting to the required amount, and function test the pressure pilot. When the desired setting is achieved, tighten the lock nut securely against the adjusting cap.
15. Connect the instrumentation tubing and the pressure connection to the monitored process.
16. Introduce pressure to the pressure pilot's control circuit and monitored process inlet. Resume normal operation.

**Figure 2: Adjusting Cap / Storage Tube Access**



**CVS 7970 High-Low Pressure Pilot**

**Table 2: Parts List**

Key	Part Number	Qty.	Description	Material
1	CVS79710A	1	Adjusting Cap	Black Delrin
2	CVS79702A	1	5/16" Ball Bearing	Stainless Steel
3	CVS7911A	1	Spring Guide	Black Delrin
4	CVS7970A	1	Spring	302 Stainless Steel
5	CVS79712A	2	Lock Nut	Black Delrin
6	CVS79709A	1	Spring Housing	316 Stainless Steel
7	CVS79708	1	Stop Plate	316 Stainless Steel
8	CVS79704A	1	Body Housing	316 Stainless Steel
9	CVS79707A	1	Upper Stem	316 Stainless Steel
10	CVS79706A	1	Lower Stem	316 Stainless Steel
11	CVS79703A	1	Small Piston	316 Stainless Steel
12	CVS79705	1	Stop Washer	316 Stainless Steel
13	CS79702	1	Large Piston	316 Stainless Steel
14	CVS797014	1	Snap Ring	304 Stainless Steel
15	CVS79701A	1	Piston Housing	316 Stainless Steel
16	V-75-010	2	Seal	Viton Coated TFE
17	V-75-008	2	Seal	Viton Coated TFE
18	V-75-119	1	Seal	Viton Coated TFE
19	TFE-008	1	Back-Up Ring	Teflon
20	V-75-008	1	Seal	Viton Coated TFE
21	CVS79713A	1	1/4" Piston	316 Stainless Steel
22	V-75-006	1	Seal	Viton Coated TFE
23	TFE-006	1	Back-Up Ring	Teflon
24	TFE-012	1	Back-Up Ring	Teflon
25	V-75-012	1	Seal	Viton Coated TFE

**Seal Kits**

CS7970-BKK	1	Piston O-Ring Kit (Body Housing)	
V-75-008	1	Seal	Viton Coated TFE
V-75-010	1	Seal	Viton Coated TFE
CVS7970-Pkk	1	Piston O-Ring Kit (Body Housing)	
V-75-006	1	Seal	Viton Coated TFE
V-75-008	1	Seal	Viton Coated TFE
V-75-012	1	Seal	Viton Coated TFE
V-75-119	1	Seal	Viton Coated TFE
TFE-006	1	Back-Up-Ring	Teflon
TFE-008	1	Back-Up Ring	Teflon
TFE-012	1	Back-Up Ring	Teflon

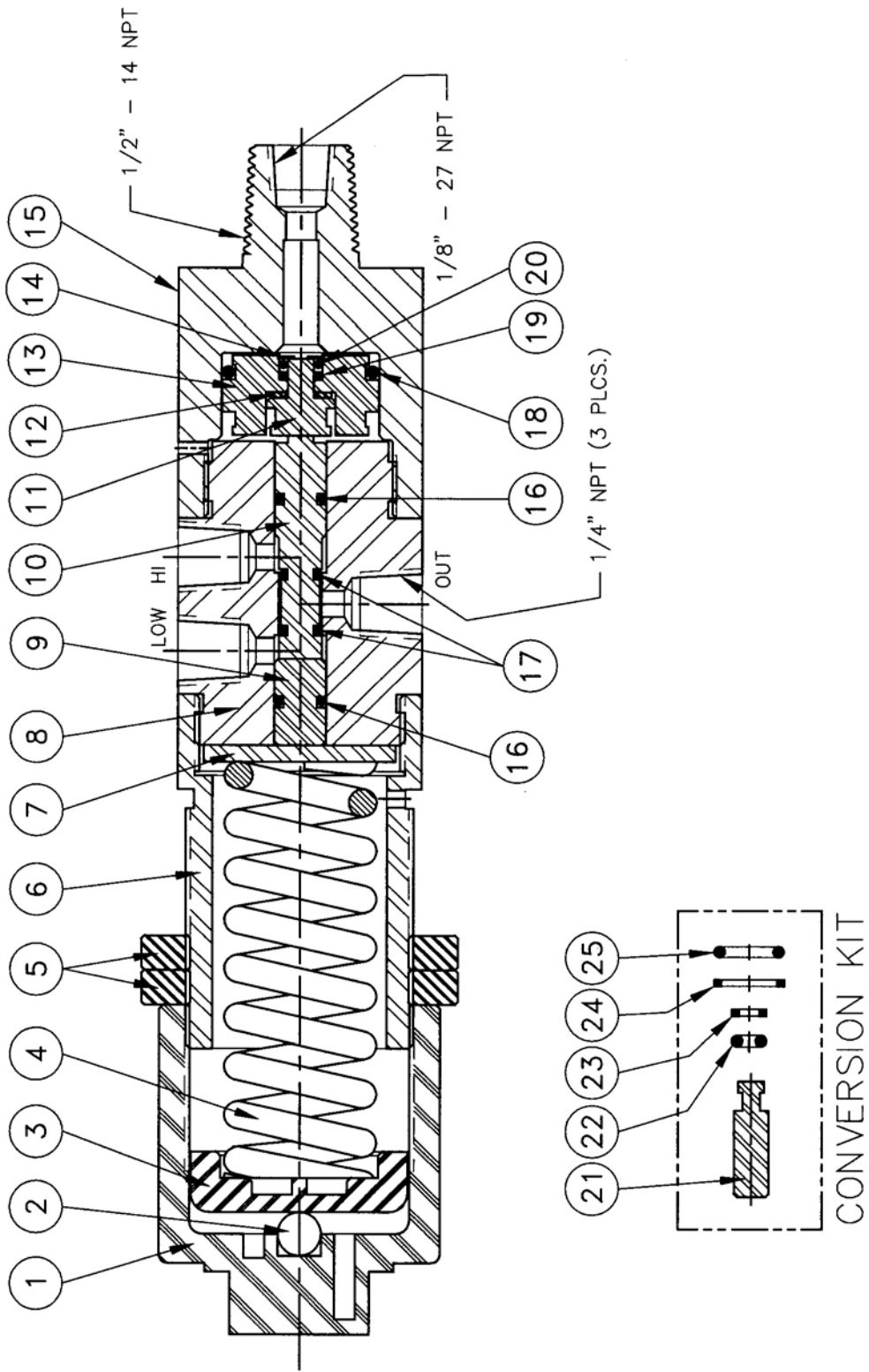
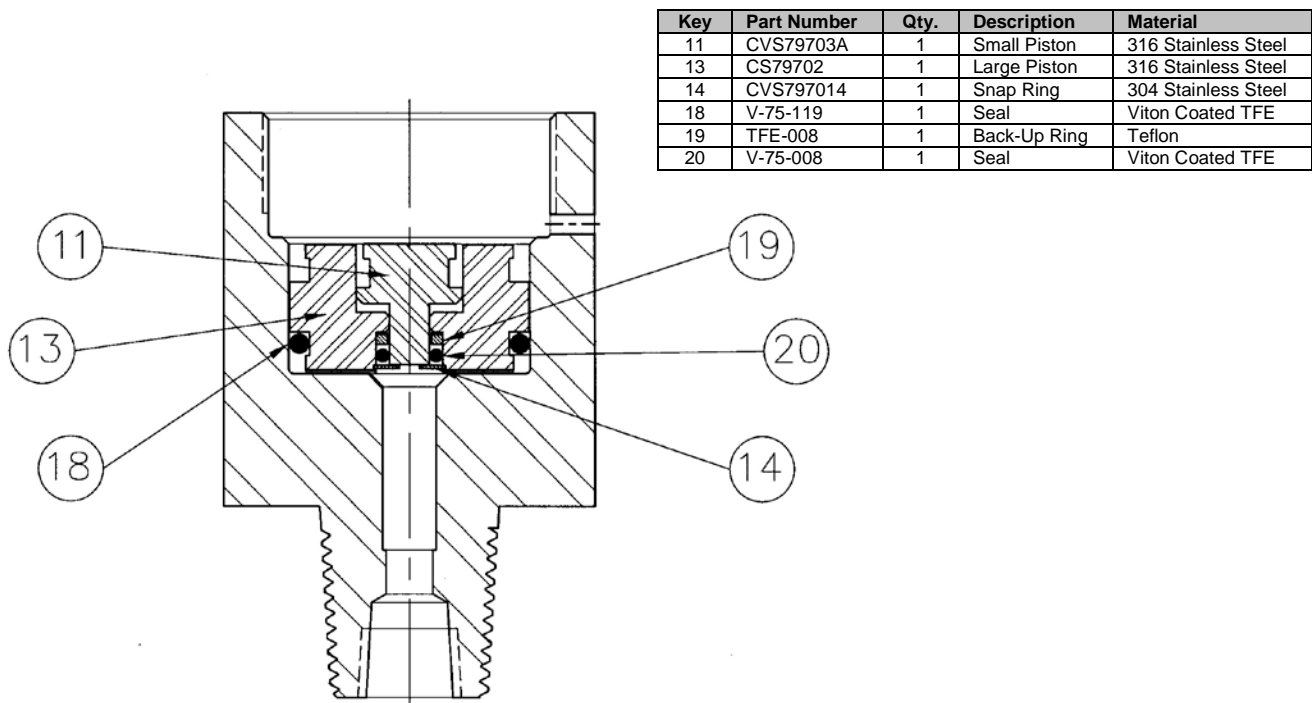
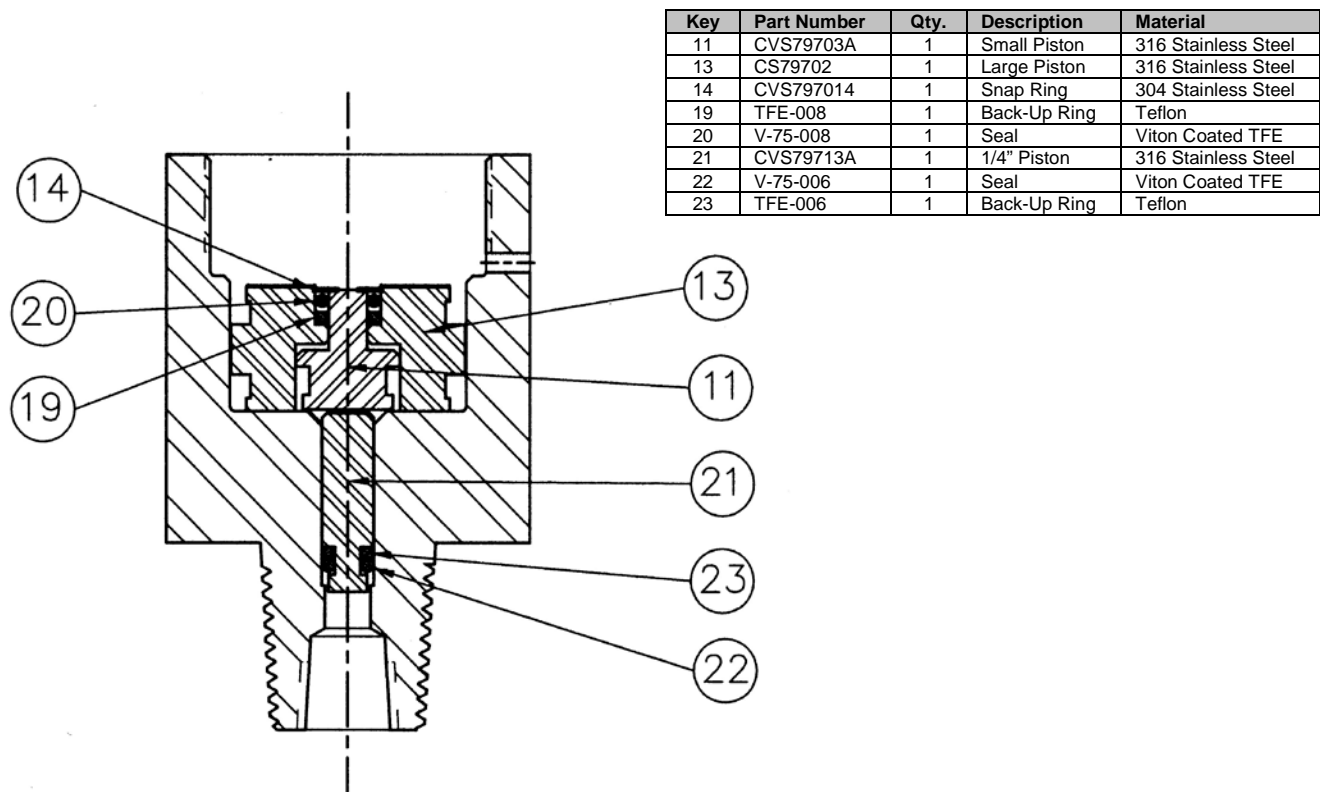


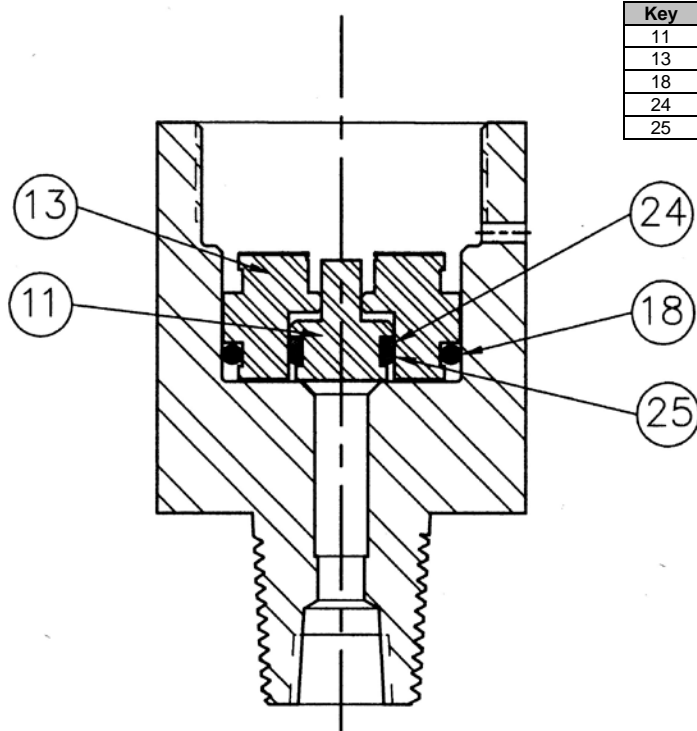
Figure 3: CVS 7970 High-Low Pressure Pilot Assembly



**Figure 4: 3/16 Piston Arrangement Enlarged Detail Drawing**  
 For pressures from 5900 to 10,000 PSI (407 to 690 bar)

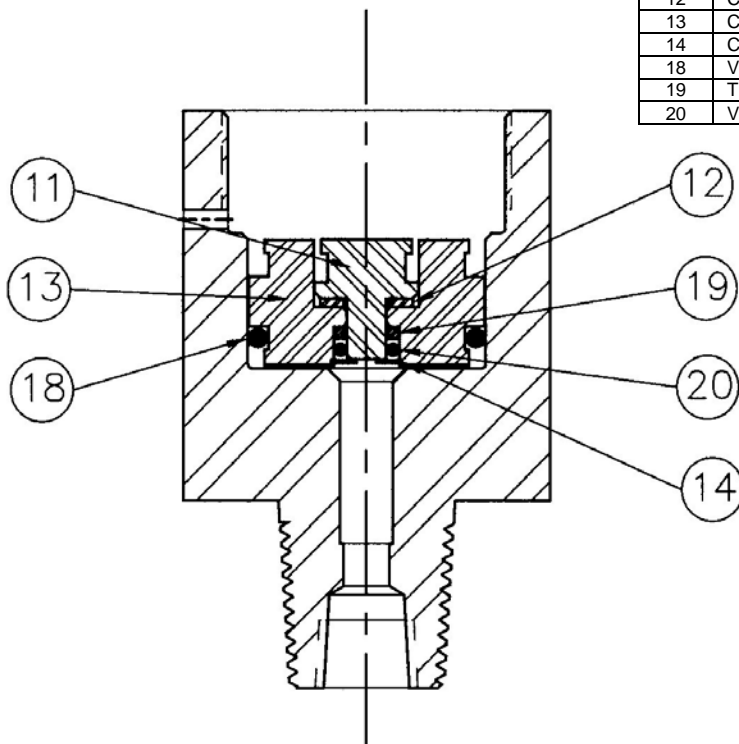


**Figure 5: 1/4" Piston Arrangement Enlarged Detail Drawing**  
 For pressures from 1440 to 5900 PSI (99 to 407 bar)



Key	Part Number	Qty.	Description	Material
11	CVS79703A	1	Small Piston	316 Stainless Steel
13	CS79702	1	Large Piston	316 Stainless Steel
18	V-75-119	1	Seal	Viton Coated TFE
24	TFE-012	1	Back-Up Ring	Teflon
25	V-75-012	1	Seal	Viton Coated TFE

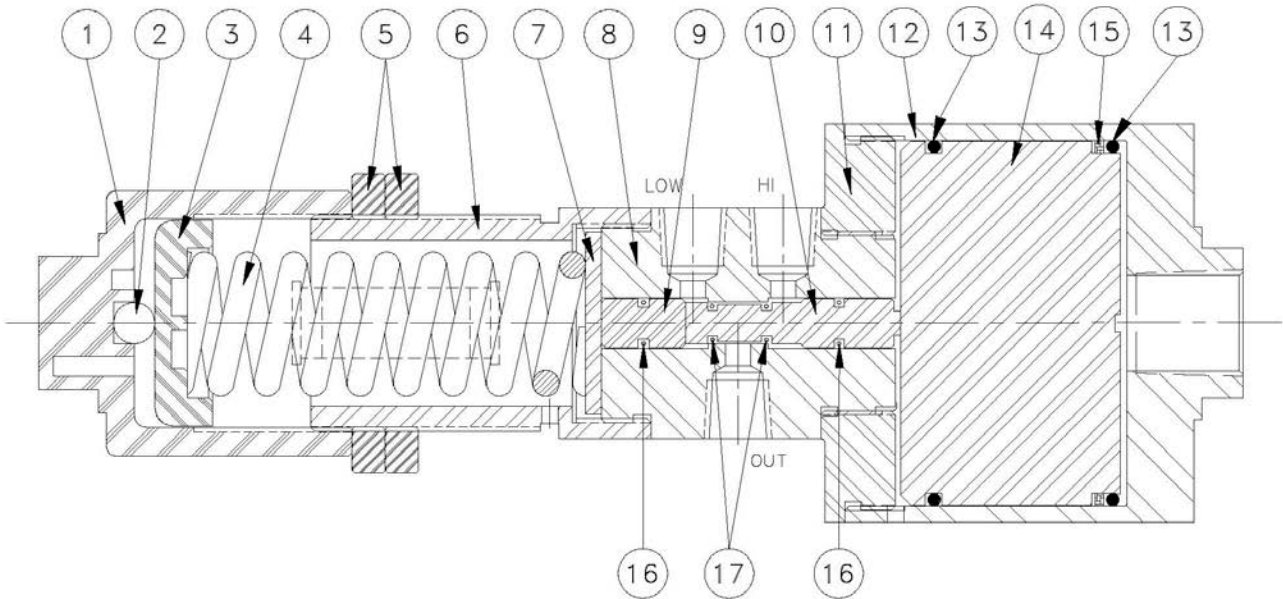
**Figure 6: 1/2" Piston Arrangement Enlarged Detail Drawing**  
For pressures from 290 to 1440 PSI (20 to 99 bar)



Key	Part Number	Qty.	Description	Material
11	CVS79703A	1	Small Piston	316 Stainless Steel
12	CVS79705	1	Stop Washer	316 Stainless Steel
13	CS79702	1	Large Piston	316 Stainless Steel
14	CVS797014	1	Snap Ring	304 Stainless Steel
18	V-75-119	1	Seal	Viton Coated TFE
19	TFE-008	1	Back-Up Ring	Teflon
20	V-75-008	1	Seal	Viton Coated TFE

**Figure 7: 1-1/8" Piston Arrangement Enlarged Detail Drawing**  
For pressures from 10 to 290 PSI (.689 to 20 bar)

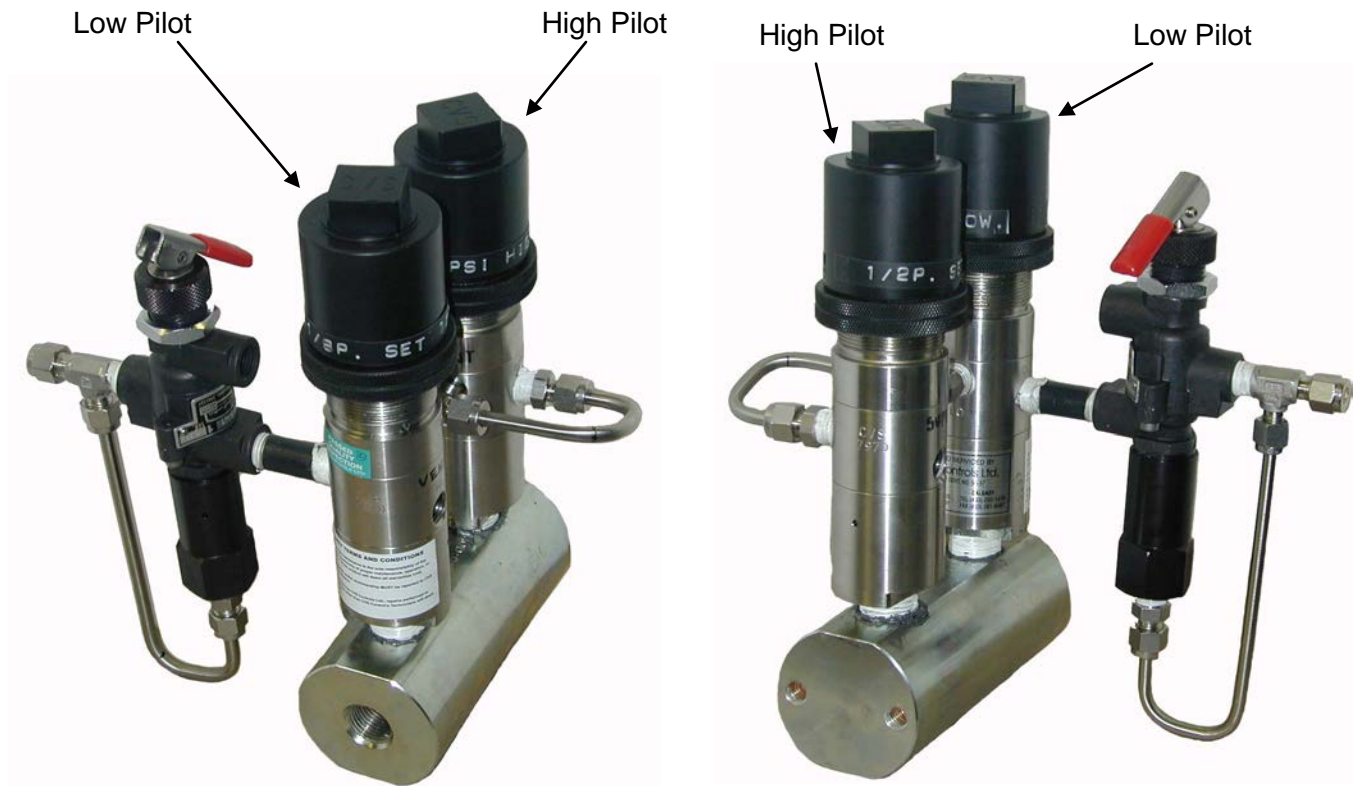
**Figure 8 – CVS Series 7970 Low Pressure Pilot – Adjustment 2 to 15 PSI, Assembly**



**CVS Series 7970 Low Pressure Pilot – Adjustment 2 to 15 PSI, Parts List**

Item Number	Part Number	Description	Qty.
1	CVS 7910A	Adjusting Cap, Black Delrin	1
2	CVS 7920A	6/16" Ball Bearing, SST	1
3	CVS 7911A	Spring Guide, Black Delrin	1
4	CVS 7970A	Spring, 302 Stainless Steel	1
5	CVS 79712A	Lock Nut, Black Delrin	2
6	CVS 79709A	Spring Housing, 316 SST	1
7	CVS 79708A	Stop Plate, 316 SST	1
8	CVS 79704A	Body Housing, 316 SST	1
9	CVS 79707A	Upper Stem, 316 SST	1
10	CVS 79706A	Lower Stem, 316 SST	1
11	CVS 79730	Adapter, Low Pressure, 316 SST	1
12	CVS 79701LP	Piston Housing, 316 SST	1
13	V-75-145	o-ring, Viton Coated TFE	2
14	CVS 79702LP	Piston, LP, 316 SST	1
15	CVS 79731	Wiper Ring, Viton	1
16	V-75-010	Seal, Viton Coated TFE	2
17	V-75-008	Seal, Viton Coated TFE	2

**Figure 9: CVS Series 7970 High-Low Pressure Pilot Switch**



**Hi-Low Pressure Pilot - Manual Reset**

Low Pressure Valve:

- \*Out Port —————> To Valve
- \*Hi Port —————> To Vent

High Pressure Valve:

- \*High Port —————> To (air/gas) Supply (Max Supply Pressure 125 psi)
- \*Low Port —————> To vent

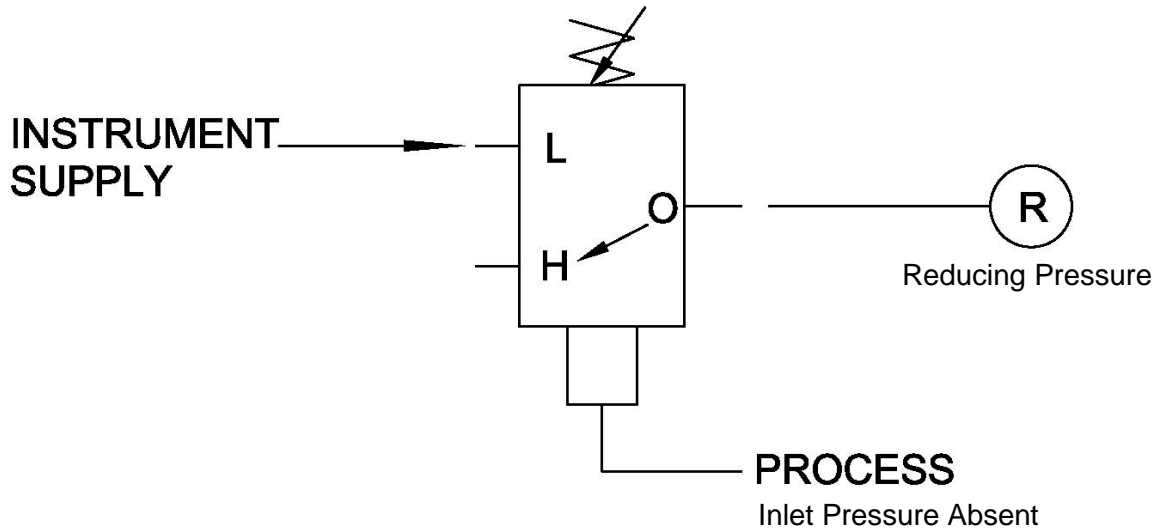
Manifold:

- \*Either port for process

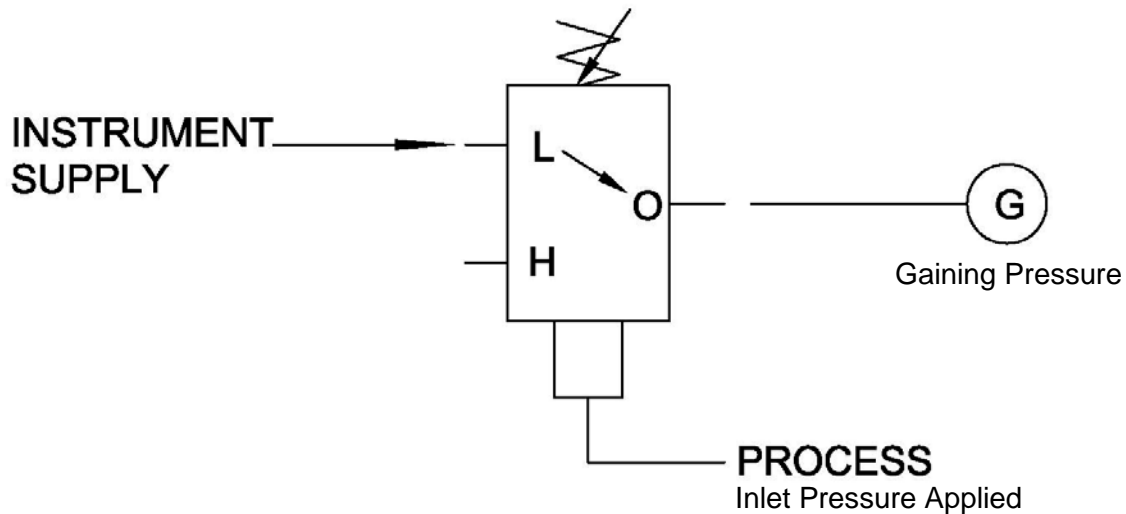


### Instructional Schematic: Pressure Sensing Low – Decreasing (PSL)

Normally Closed – Loss of Instrument (output) pressure, when sensed inlet pressure decreases below the low pressure setting.



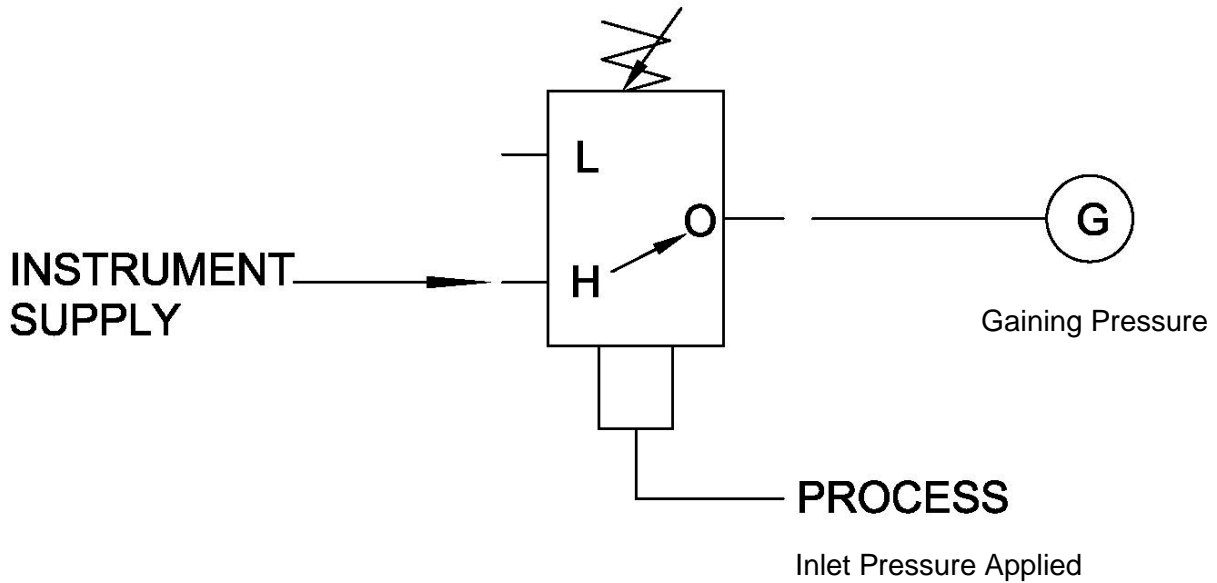
Unactuated - Monitored process control pressure has DECREASED below the Low Pressure Setting, or is absent.



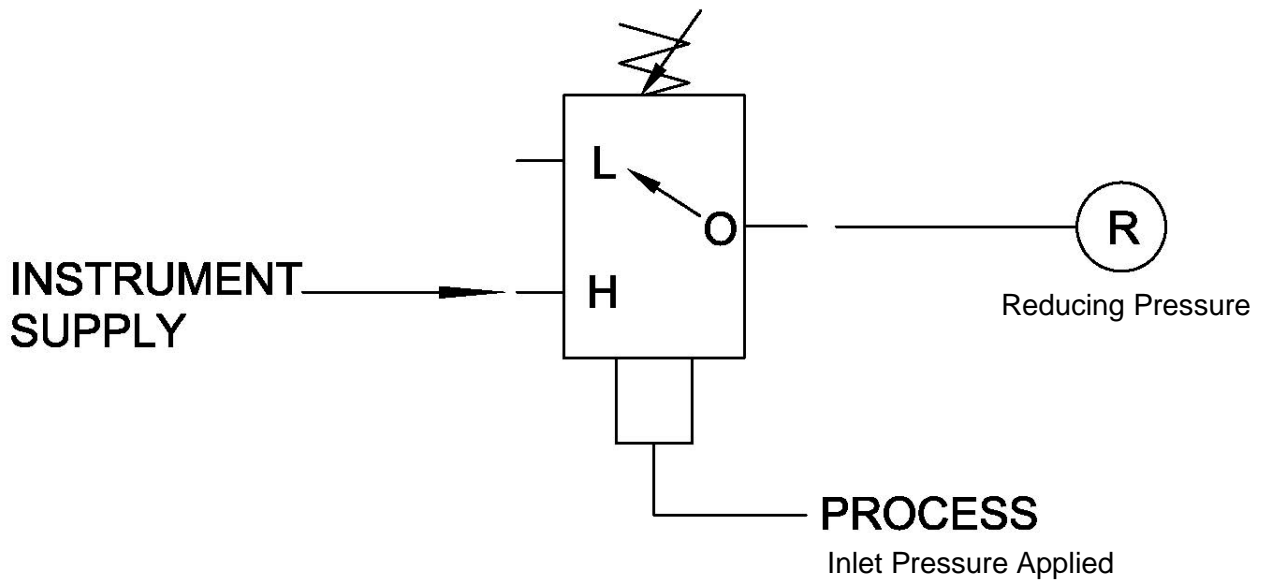
Actuated - Monitored process control pressure has INCREASED above the Low Pressure Setting. Normal operation.

### Instructional Schematic: Pressure Sensing High – Increasing (PSH)

Normally Open – Loss in Instrument (output) pressure, when sensed inlet pressure increases above the high pressure setting.



Unactuated - Monitored process control pressure is applied, but is BELOW the high pressure setting. Normal operation.



Actuated – Monitored process control pressure has INCREASED ABOVE the high pressure setting.

**Notes:**

# CVS

---

---

## Controls Ltd.

**Head Office**

3900 – 101 Street  
Edmonton, Alberta, Canada T6E 0A5  
Office: (780) 437-3055  
Fax: (780) 436-5461

**Calgary Sales Office**

205, 2323 – 32 Avenue NE  
Calgary, Alberta, Canada T2E 6Z3  
Office: (403) 250-1416  
Fax: (403) 291-9487

Website: [www.cvs-controls.com](http://www.cvs-controls.com) E-Mail: [info@cvs-controls.com](mailto:info@cvs-controls.com)

CVS Controls Ltd. strives for the highest levels of quality and accuracy. The information included in this publication is presented for informational purposes only. CVS Controls Ltd. reserves the right to modify or change, and improve design, process, and specifications without written notice. Under no circumstance is the information contained to be interpreted to be a guarantee/warranty with regard to our products or services, applicability or use. Selection, use and maintenance are the sole responsibility of the end user and purchaser. CVS Controls assumes no liability for the selection use and maintenance of any product.